

HALLEY BKA 2000

Operating manual

DM318010

vers. 3.0



© 2002 SILCA S.p.A - Vittorio Veneto

This manual has been drawn up by ILCO ORION

All rights reserved. No part of this publication may be reproduced or used in any form or by any means (photocopying, micro-film or other) without the written permission of ILCO ORION.

Edition: june 2006

Printed in Vittorio Veneto
by ILCO ORION
via Podgora, 20 (Z.I.)
31029 VITTORIO VENETO (TV) - Italy

INDEX

	GUIDE TO THE MANUAL	5
	GENERAL INSTRUCTIONS	6
1	TRANSPORT	7
	1.1 Packing	7
	1.2 Transport	7
	1.3 Unpacking	7
	1.4 Machine handling	7
2	WORKING PARTS	8
3	MACHINE DESCRIPTION	9
	3.1 Technical data	9
	3.2 Electrical circuit	10
4	ACCESSORIES PROVIDED	11
5	MACHINE INSTALLATION AND PREPARATION	12
	5.1 Checking for damage	12
	5.2 Environmental conditions	12
	5.3 Positioning	12
	5.4 Description of work station	12
	5.5 Graphics	13
	5.6 Separate parts	13
	5.7 Connection to the mains	13
6	REGULATION AND USE OF THE MACHINE	14
	6.1 Setting	14
	6.1.1 Adjusting the cutting depth	14
	6.1.2 Setting the cutting spaces	15
	6.1.3 Setting the cutting height	15
	6.2 Cutting operations	16
	6.3 Key cutting	16
	6.4 BIT and DOUBLE BIT keys (side 1)	18
	6.5 Pump keys (side1)	19
7	MAINTENANCE	20
	7.1 Cutting tool replacement	20
	7.2 Tracer point replacement	20
	7.3 Replacing the fuses	21
8	DISPOSING OF MACHINE	22
9	AFTER-SALES SERVICE	23
	9.1 How to request service	23

GUIDE TO THE MANUAL

This manual has been produced to serve as a guide for users of the HALLEY BKA 2000 key-cutting machine. Read it carefully; it is essential if you wish to operate your machine safely and efficiently.

Consultation

The contents of the manual are divided into sections relating to:

- Transport and handling
- Description of machine and safety devices
- Proper use of the machine
- Maintenance

Technical terms

Common technical terms are used in this manual. To assist those with little experience of key cutting, below is an illustration of the terms used for the different parts of keys:

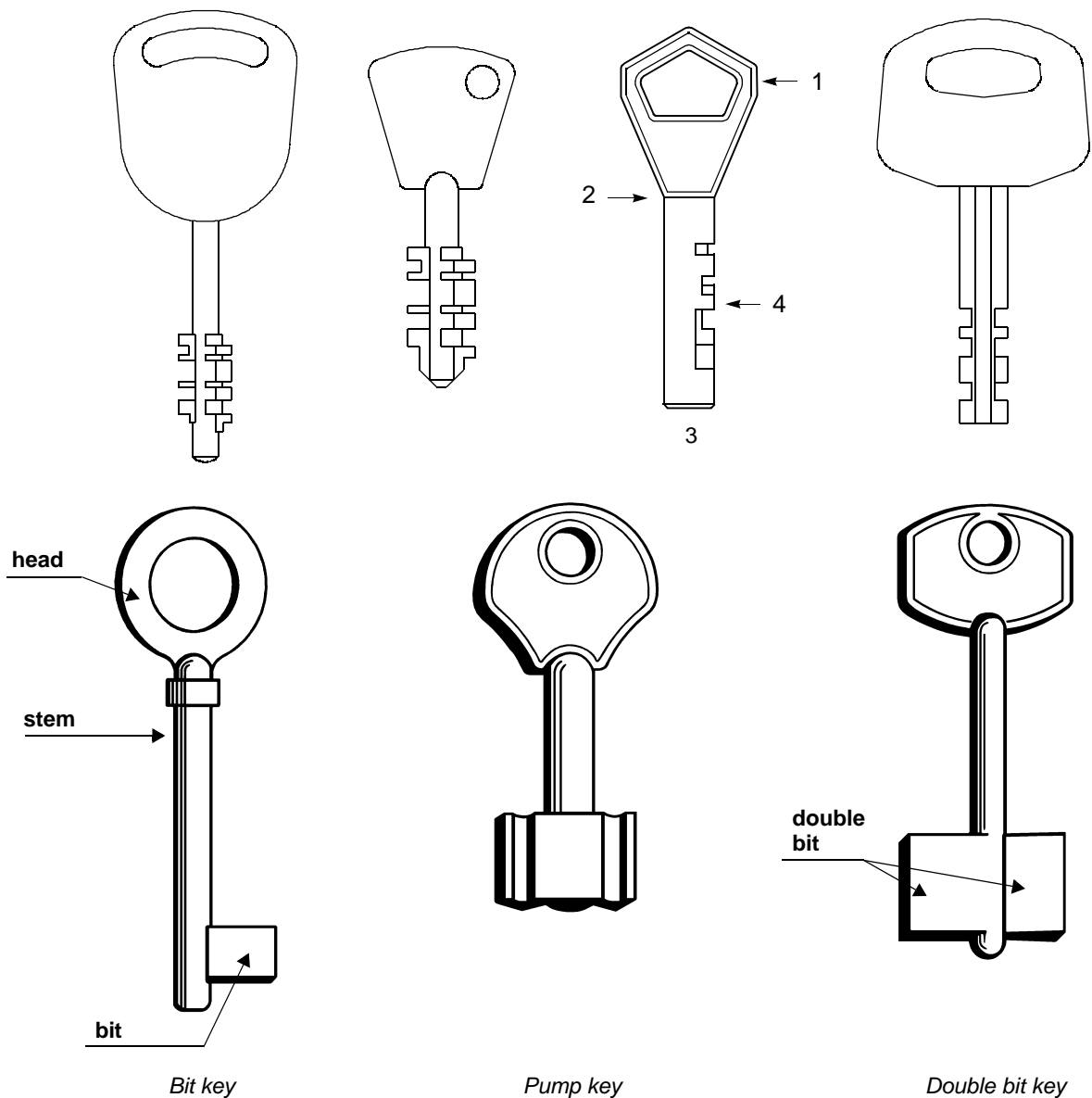

Fig. 1

- 1) Head
- 2) Rim
- 3) Tip
- 4) Cuts

GENERAL INSTRUCTIONS

The HALLEY BKA 2000 key-cutting machine has been designed according to the specifications of the Machine Directives. From the design stage risks for the operator have been eliminated in all areas: transport, regulation, cutting and maintenance.

The use of protective goggles is compulsory during cutting operations, as indicated on the machine itself and in this manual.

The material used in the manufacture of this machine and **the components employed during use of the machine are not dangerous and their use complies with standards.**

Use

The HALLEY BKA 2000 key-cutting machine must be installed and used in the way laid down by the manufacturer, as illustrated in this manual.

If the machine is used differently or for purposes different from those described in this manual, the customer will forego any rights he may have over Ilco Orion. Furthermore, unforeseen danger to the operator or any third parties may arise from incorrect use of the machine.

Negligence in the use of the machine or failure on the part of the operator to observe the instructions given in this manual are not covered by the guarantee and the manufacturer declines all responsibility in such cases.

It is therefore indispensable to read the operating manual carefully in order to make the best use of the HALLEY BKA 2000 key-cutting machine and benefit from its potential.

Further risks

There are no further risks arising from the use of the HALLEY BKA 2000 key-cutting machine.

Protection and safety precautions for the operator

The HALLEY BKA 2000 key-cutting machine is built entirely to standards. The operations for which it has been designed are easily carried out at no risk to the operator.

The adoption of general safety precautions (use of protective goggles) and observation of the instructions provided by the manufacturer in this manual eliminate all human error, unless deliberate.

The HALLEY BKA 2000 key-cutting machine is designed with features which make it completely safe in all its parts.

- **Power supply**

The key-cutting machine must be supplied with electricity by means of a safety device (standard with 230V key-cutting machines). **The plug must be earthed.**

- **Start-up**

The machine is started up by means of:

- 1) the main switch on the safety device (standard with 230V key-cutting machines, on request for other voltages);
- 2) the ON switch, situated on the machine, which activates the machine motor.

- **Maintenance**

The operations to regulate, service, repair and clean the machine have been devised in the simplest and safest way possible. There is no danger of removable parts being replaced wrongly or unsafely.

- **Machine identification**

The HALLEY BKA 2000 is provided with an identification label which shows the serial number (fig.2).

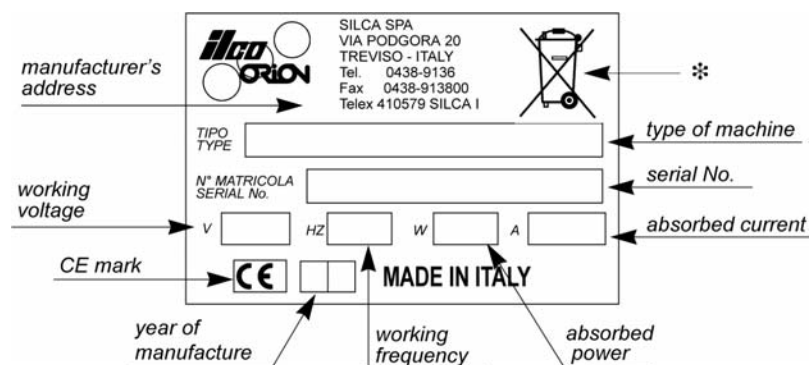

Fig. 2

(*) see chap. 8 DISPOSING OF MACHINE, page 22.

1 TRANSPORT

The HALLEY BKA 2000 key-cutting machine is easily transported and is not dangerous to handle. The packed machine can be carried by one person.

1.1 Packing

The HALLEY BKA 2000 key-cutting machine comes in a strong cardboard box, the dimensions of which are shown in fig.3, designed to protect the machine and all its parts even when it is stored for long periods.

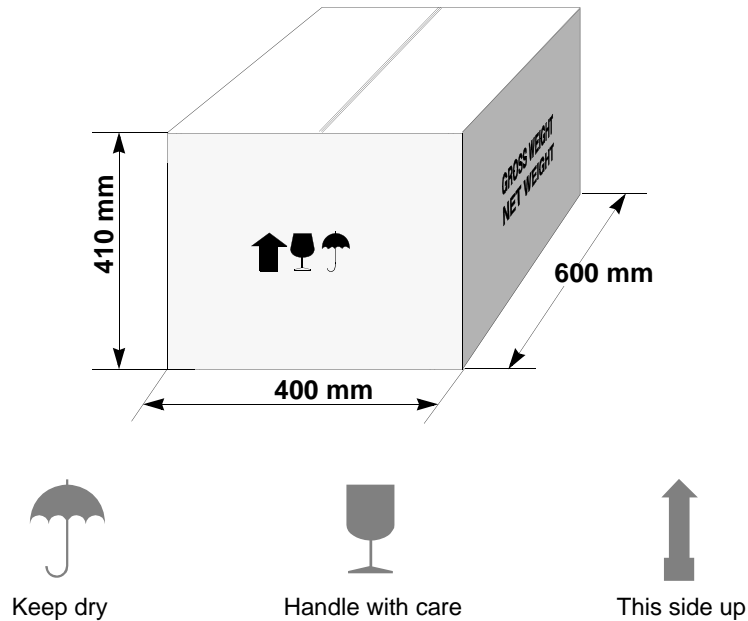

Fig. 3

1.2 Transport

It is advisable to use the packing every time the machine is transported, as this will avoid knocks which could cause damage to the machine, persons or things.

1.3 Unpacking

To remove the machine from the packing box:

- 1) cut the straps with scissors and remove,
- 2) open the box without damaging it as it may be used again (e.g. removals, dispatch to the manufacturers for repairs or servicing),
- 3) check the contents of the box, which should comprise:
 - 1 HALLEY BKA 2000 key-cutting machine;
 - 1 safety device (standard with 230V key-cutting machines);
 - set of documents, including: operating manual, spare parts list and guarantee;
 - 1 set of accessories.

1.4 Machine handling

When the HALLEY BKA 2000 key-cutting machine has been unpacked, place it directly on its workbench.

This operation can be carried out by one person, **firmly holding the base, and no other part, to lift and carry the machine.**

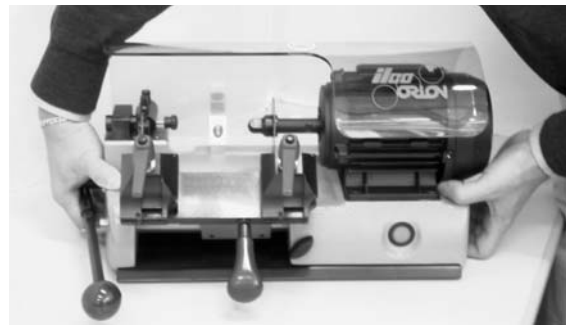

Fig. 4

2 WORKING PARTS

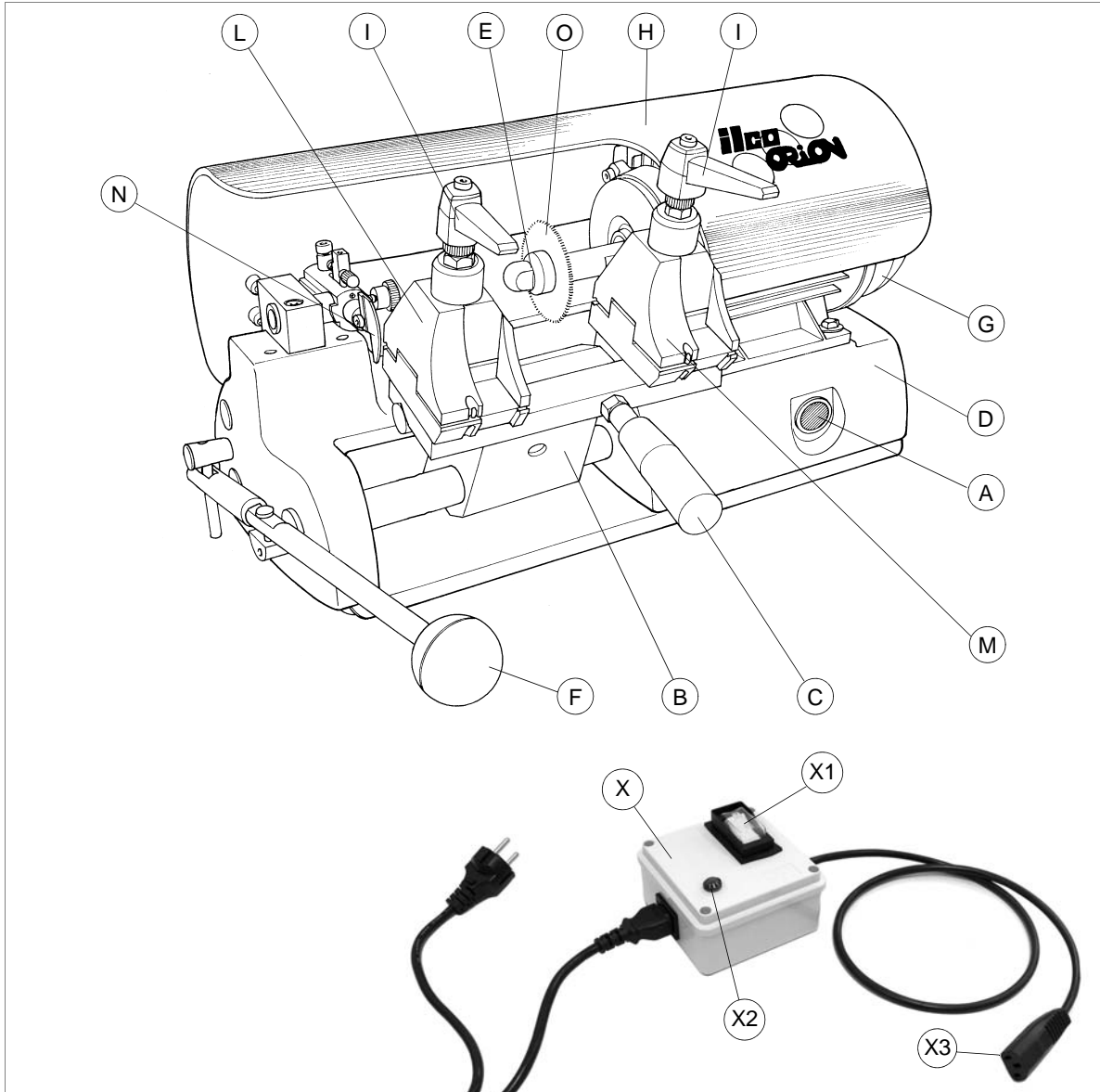

Fig. 5

- A - Main switch
- B - Clamp carriage
- C - Carriage lever
- D - Base
- E - Cutter nut
- F - Lateral movement lever
- G - Motor
- H - Cutter protection
- I - Key fastening knob
- L - Clamp, tracer side
- M - Clamp, cutter side
- N - Tracer
- O - Cutter

- X - Safety device (standard with 230V key-cutting machines)
- X1- Safety main switch
- X2- Warning light
- X3- Plug

3 MACHINE DESCRIPTION

HALLEY BKA 2000 is a professional key-cutting machine for ABLOY® - ABUS GRANIT® / PLUS® - AVA CHUBB® - FORD CHUBB® - IFAM - LUMA® - BIT - DOUBLE BIT - PUMP keys. The machine comprises the following main parts:

Safety device (standard with 230V key-cutting machines)

The device is connected to a power plug with a differential switch, power the key-cutting machine by pressing the switch (X1).

The warning light (X2) illuminates to indicate voltage in the plug (X3).

ATTENTION: switch (X1) is electromagnetic, in the event of a power failure it goes out automatically. When electricity is restored it must be reset manually to power the machine again by means of the plug (X3).

Master switch

The motor starting button is placed on the right side of the motor of the HALLEY BKA 2000 key-cutting machine.

ATTENTION: the switch is illuminated to indicate that the machine is live.

Motor

The HALLEY BKA 2000 has a direct drive motor (G). The transmission unit comprises the motor and cutter is protected by a single cover (H).

Mobile unit

The mobile unit comprises a carriage (B) holding the clamps.

The carriage (B) is fitted to the translation shaft and is moved manually by the operator.

It has been designed to avoid the accumulation of cutting dust or chippings.

- **Cutting tool (O)**

The cutting tool is the part of the HALLEY BKA 2000 machine which cuts the key blank. The tool is in HSS super rapid steel and is protected by a special cover (H) to ensure safe operation.

- **Tracer point (N)**

The tracer point is housed on the left-hand side of the machine base. Its depth settings are easily regulated.

3.1 Technical data

ELECTRICAL PROPERTIES:	230V - 50Hz 190W 2A; 110V - 60Hz 190W-5A.
CUTTING TOOL:	Super Rapid Steel (HSS)
MOTOR:	One speed single phase; 230V-50Hz 1350 rpm 0,18 kW; 110V - 60Hz 1680 rpm 0,18 kW.
CLAMP:	2 sides
CARRIAGE MOVEMENT:	manual
DIMENSIONS:	width: 470 mm, depth: 350 mm, height: 260 mm
CUTTING NOISE:	Lp (A) = max. 99,7 dB (A)
WEIGHT:	Kg. 26

3.2 Electrical circuit

The HALLEY BKA 2000 key-cutting machine is provided with a single phase one-speed motor:

- 1350 rpm, consumes approximately 0.18 Kw, absorption 2A;
- 1680 rpm, consumes approximately 0.18 Kw absorption 4,3A

The main parts of the electric circuit on the HALLEY BKA 2000 are listed below:

- 1) Safety device inlet
- 2) Safety main switch
- 3) Warning light
- 4) Wiring clip
- 5) Machine inlet
- 6) Rapid fuses 4A (230V) - 10A (110V)
- 7) Illuminated switch
- 8) Motor: 230V a.c. 50Hz - 110V a.c. 60Hz
- 9) Condenser 8 μ F (230V) - 20 μ F (110V)



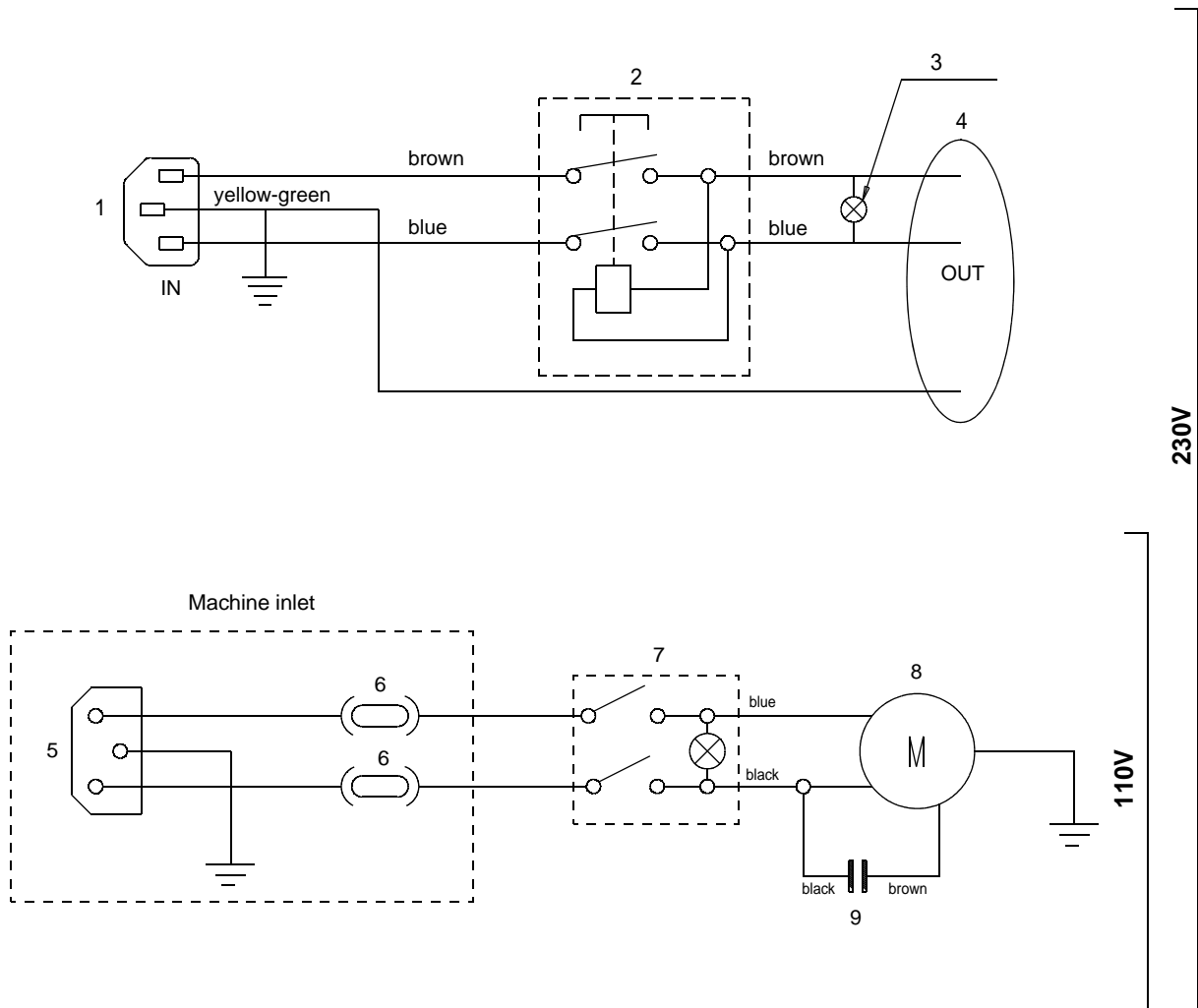

Safety device (standard with 230V key-cutting machines)

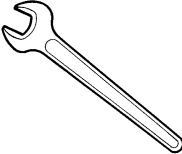

4 ACCESSORIES PROVIDED

To ensure trouble-free working with the HALLEY BKA 2000, it is advisable to always have certain spare parts on hand.

It is advisable to always have a tool box containing: tools, cutting tools, and small replacement parts. HALLEY BKA 2000 is supplied with a full range of accessories. The accessories provided by Ilco Orion are all that is necessary to carry out the operations for which the machine is designed.

 <p>code D300221ZZ 2 mm ALLEN KEY</p>	 <p>code DMS200340 13/17/19 mm SPANNER 2 pcs</p>
 <p>code D300223ZZ 3 mm ALLEN KEY</p>	 <p>code DEM306054 Setting up pins 6 x 50 mm 2 pcs</p>
 <p>code D301185ZZ (230V) FUSES 5x20 4A-rapid</p> <p>code D309997ZZ (110V) FUSES 5x20 10A-rapid</p>	

5 MACHINE INSTALLATION AND PREPARATION

The HALLEY BKA 2000 key-cutting machine can be installed by the purchaser and does not require any special skills. However, some checks and preparation for use need to be carried out by the operator.

5.1 Checking for damage

The HALLEY BKA 2000 is solid and compact and will not normally damage if transport, unpacking and installation have all been carried out according to the instructions on the packing box. However, it is always advisable to check that the machine has not suffered any damage.

5.2 Environmental conditions

To ensure that the best use is made of the key-cutting machine, certain parameters must be borne in mind:

- damp, badly ventilated sites should be avoided.
- the conditions for the machine are:
 - temperature: between 0 and 40°C
 - relative humidity: approx 60%

5.3 Positioning

Place the machine on a horizontal surface, solid enough to take the weight (26 Kg). To facilitate operation and maintenance, install the machine with a clearance of at least 300 mm on all sides (fig.6). Check that the weight of the machine is evenly distributed over the four feet; horizontal positioning prevents vibrations during operation.

ATTENTION: ensure that the machine voltage is the same as that of the mains, which must be properly earthed and provided with a differential switch.

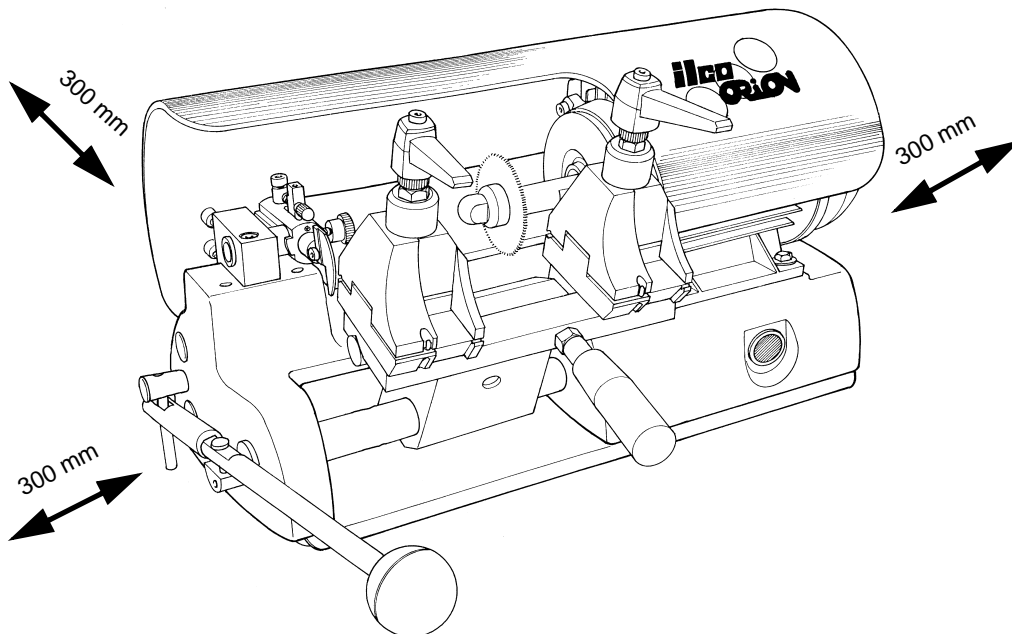

Fig. 6

5.4 Description of work station

The machine needs only one operator, who has the following controls at his/her disposal:

- **Master switch (A)**, placed on the left-hand side of the motor; provided with a warning light indicating that the machine is live.
- **Carriage lever handle (C)**.
- **Lateral movement lever (F)**.

5.5 Graphics



THE USE OF PROTECTIVE GOGGLES
IS COMPULSORY

5.6 Separate parts

The detachable parts of the machine are packed separately and must be fitted to the HALLEY BKA 2000 by the operator, as follows:

Power cable

230V version:

first connect the safety device (X) to the key-cutting machine and the power cable then connect the free end of the power cable to the power mains (Fig. 7).

110V version:

connect the key-cutting machine and the power cable then connect the free end of the power cable to the power mains (Fig. 7).

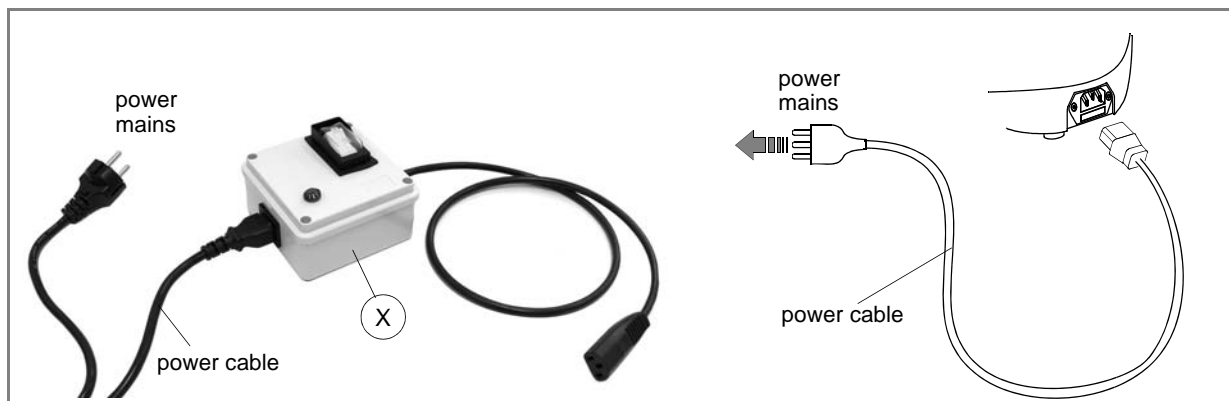

Fig. 7

5.7 Connection to the mains

It is extremely important for the operator's safety to ensure that the key-cutting machine is connected to the power mains with the right voltage and **by means of a properly earthed differential switch.**

6 REGULATION AND USE OF THE MACHINE

The cutting tool on the HALLEY BKA 2000 is used to cut the key blanks and must be periodically checked and replaced. Periodically, and whenever the cutting tool is replaced, check the key-cutting machine settings, to ensure perfect machine efficiency.

6.1 Setting

6.1.1 Adjusting the cutting depth

- 1) Insert the supplied gauges horizontally in the clamp housings (side 1) (fig.8).
- 2) move the carriage and make sure the tracer is well pressed against the gauge.
- 3) turn the cutter manually.
- 4) the cutting depth of the machine is correct when the cutter skims the gauge freely. Otherwise proceed as follows:
 - loosen the screw (J1) (fig.9).
 - turn the screw (K1) (tighten it or loosen it until the cutter skims the gauge).
 - fasten the screw (J1) (fig. 19, page 20).

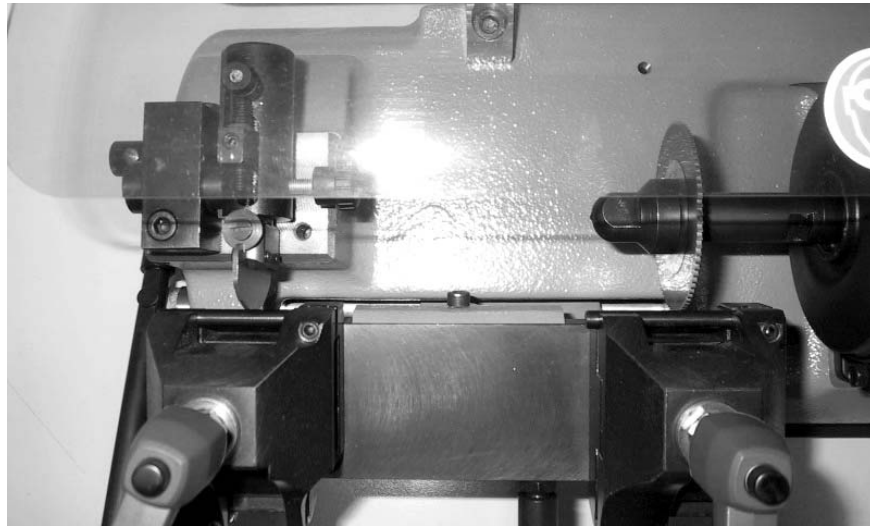

Fig. 8

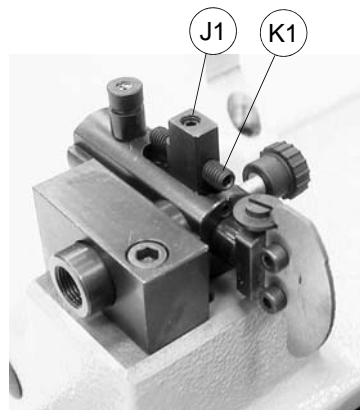

Fig. 9

6.1.2 Setting the cutting spaces

ATTENTION: first carry out depth gauging then this gauging operation.

- 1) Insert the supplied gauges vertically in the clamps (side 1) (fig. 13, page 16).
- 2) move the clamp carriage until the tracer touches the gauge (fig.10).
- 3) turn the cutter manually.
- 4) the cutting interval is correct when the cutter skims the gauge in the right clamp (M). Otherwise proceed as follows:
 - loosen the screw (N1) of the tracer unit (fig.11).
 - move the tracer unit next to the gauge in the left clamp (L).
 - fasten the screw (N1).
 - make sure the above mentioned condition occurs before the adjustment of the machine can be considered correct.

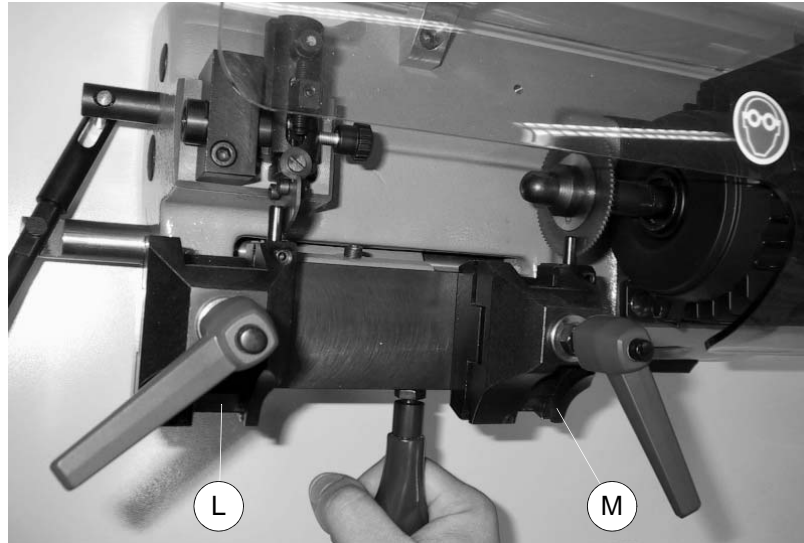

Fig. 10

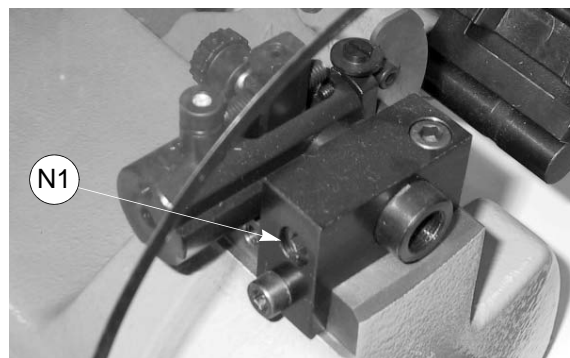

Fig. 11

6.1.3 Setting the cutting height

As for depth gauging. The cutter must skim the gauge evenly, independently of the point of contact with the tracer point.(in the centre, at the top, at the bottom). If this is not so, loosen the screws (K) and adjust screw (J) until ideal gauging is achieved (fig.12).

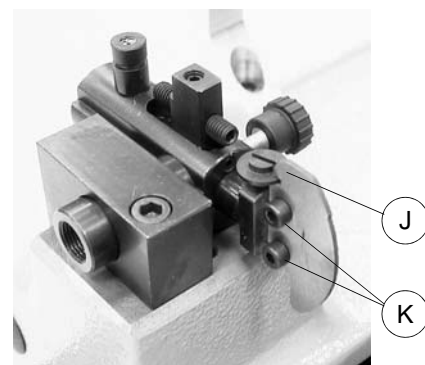

Fig. 12

6.2 Cutting operations

To work in complete safety, pay special attention to the following recommendations:

- **Always work with dry hands.**
 - **Check that the machine is properly earthed.**
 - **Use the protective goggles, even if the cutting tool is fitted with a protective shield.**
 - **Start the motor only when all the operations with the carriage have been carried out (securing keys, etc.).**
 - **Keep hands away from the cutting tool when in motion.**
- 1) After having connected the machine to the mains, press the main switch (A) (fig. 5, page 8).
 - 2) move the clamp unit towards the cutter unit using the lever (F).
 - 3) for cutting the keys, use one of the sides of the clamp according to the type of key (chap. 6.3, page 16). Turn the clamp to the desired side; proceed as follows:
 - a) loosen the clamp fastening knob (I) by turning it anticlockwise until the pins protrude from the guide.
 - b) turn the clamps (L) and (M) and position them as desired.
 - c) tighten the clamp fastening knob (I) until the clamps are fastened.

6.3 Key cutting

- 1) Position the sample key into the left clamp (L) and fasten it; position the key blank into the right (M) and fasten it.
- 2) turn the machine on using the switch (A).

Important: move the carriage by raising the knob (C), this makes it move towards the cutter with the key tilted thus aiding the cut, using the lever (F).

- 3) carry out the cut.
- 4) there may be different types of key to cut and therefore different references. The keys are to be positioned in the clamps in the way described in fig.14,fig.15, fig.16 and fig.17.

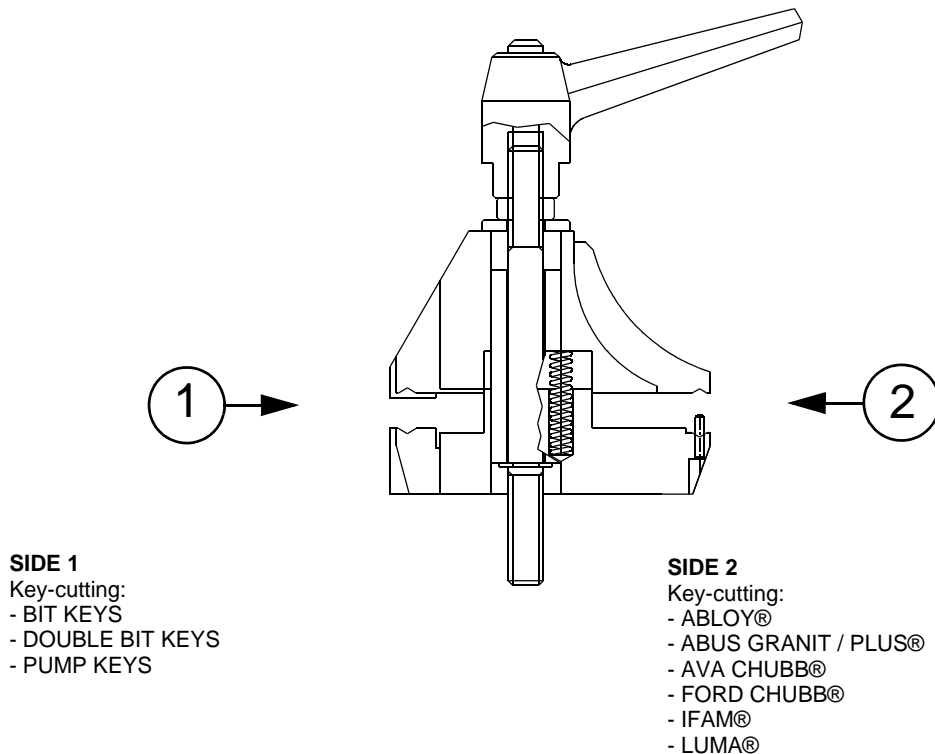

Fig. 13

Fig. 14: keys with tip reference (side 2)

- 1) place the tip of the key against the reference pin.
- 2) fit the key in the horizontal position.

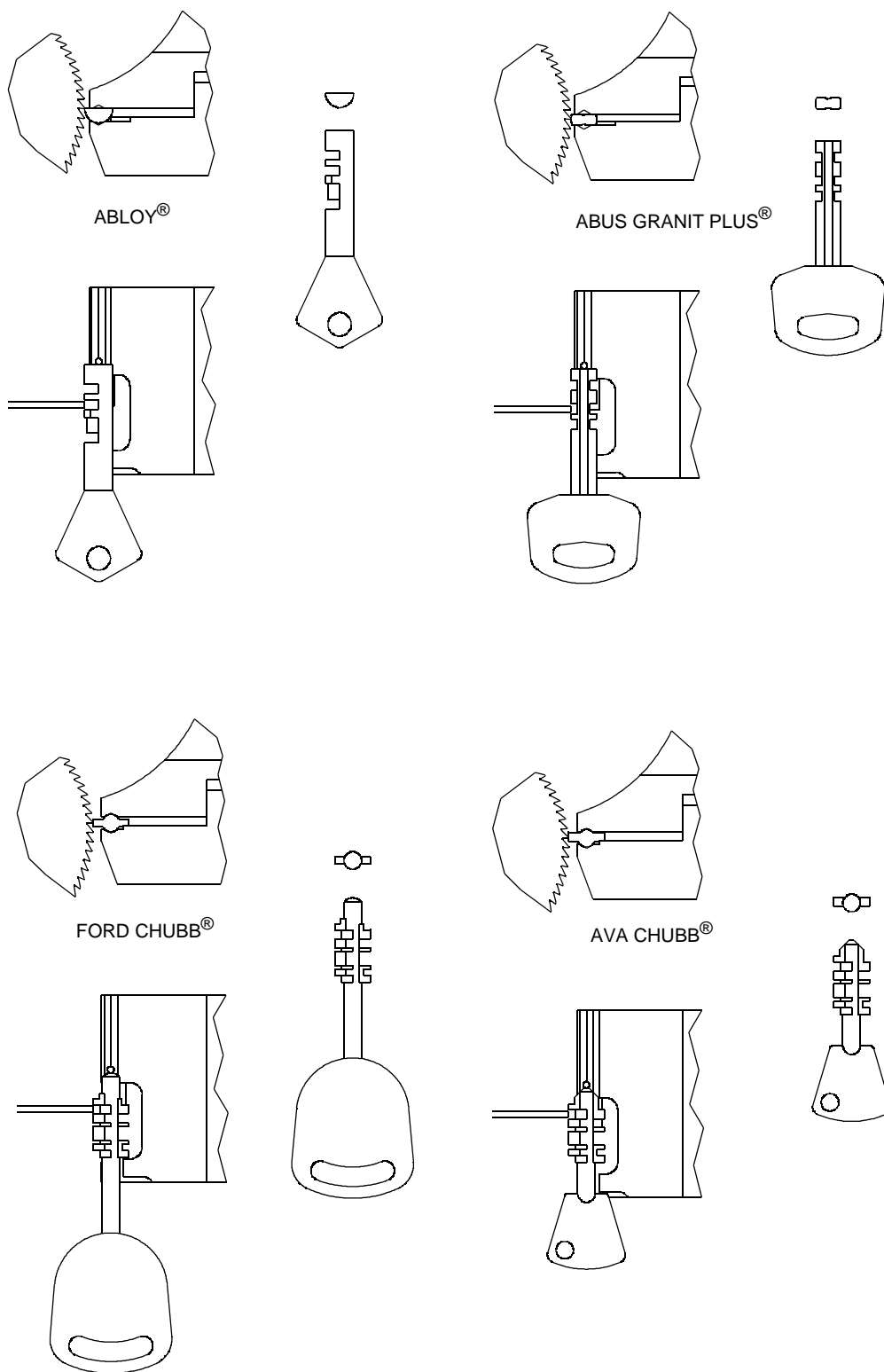

Fig. 14

Fig. 15: keys with tip reference (side 2)

- 1) place the tip of the key against the reference pin.
- 2) fit the key in the vertical position.

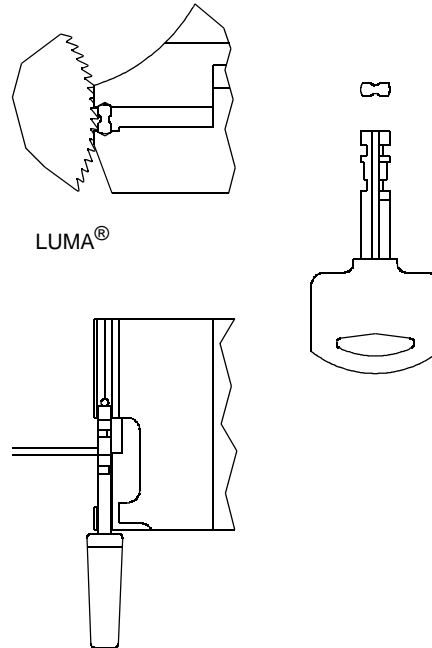

Fig. 15

6.4 BIT and DOUBLE BIT keys (side 1)

- 1) Place the sample key into the left clamp (L) and fasten it, place the key blank into the right clamp (M) without fastening it.
- 2) using the (F) and (C) levers, move the bit of the key towards the tracer.
- 3) place the bit of the key to be cut against the cutter and fasten it.
- 4) loosen the carriage and turn the machine on using the (A) switch.

Important: move the carriage by raising the knob (C), this makes it move towards the cutter with the key tilted thus aiding the cut.

- 5) carry out the cut.
- Round the cuts by tilting the (C) knob from top to bottom.

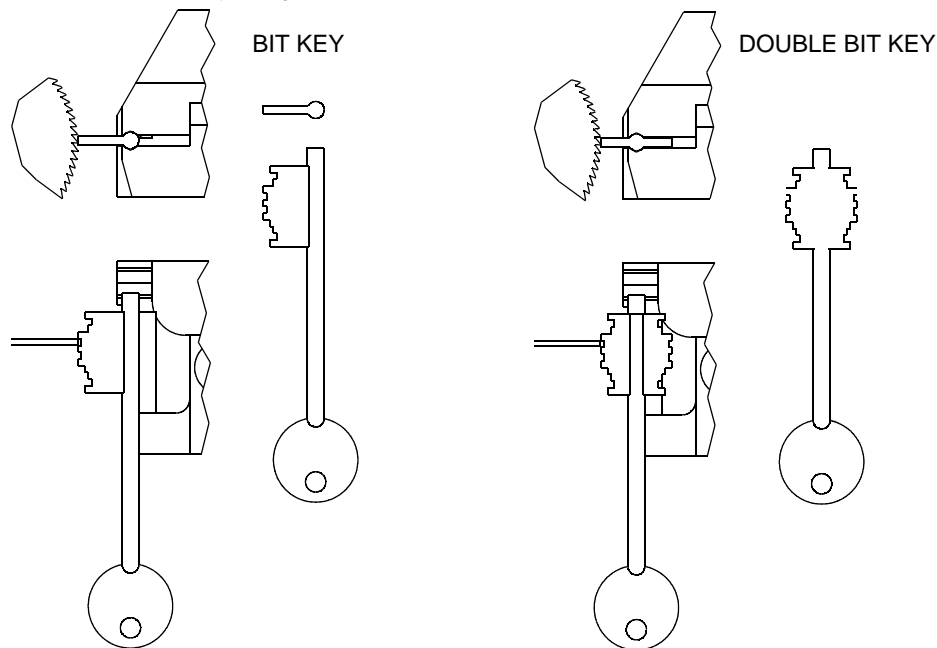

Fig. 16

6.5 Pump keys (side1)

- 1) Loosen the clamp fastening knob (I) raise it and turn it to the desired position.
- 2) insert the sample key into the "V" shaped housing of the left clamp (L), make sure it presses against the side of the clamp and fasten it.
- 3) in the same way fasten the key blank in the right clamp (M).
- 4) carry out the cut.

Important: for flat pump keys proceed as follows:

- 5) place the key in the clamp without fastening it.
- 6) fasten the key using the screw "X" situated at the top of the clamp.

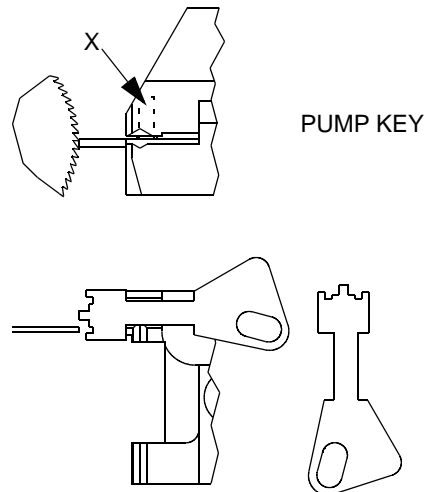

Fig. 17

7 MAINTENANCE

Although the HALLEY BKA 2000 key-cutting machine does not require special maintenance, it is advisable to check and, if necessary, replace the parts subject to wear (cutting tool, tracer point). Replacement is simple and can be carried out by the operator.

CLEANING: it is advisable to use a soft brush to keep the carriage and clamps free of chippings from cutting operations.

ATTENTION: DO NOT USE COMPRESSED AIR!

Before starting any type of maintenance (checks or replacements), read the instructions below:

- **never carry out maintenance or servicing with the machine switched on.**
- **always remove the mains plug.**
- **follow all the instructions in the manual to the letter.**
- **use original spare parts.**
- **always check that any screws or nuts removed when replacing a piece are properly tightened.**

7.1 Cutting tool replacement

Using the supplied tools proceed as follows:

ATTENTION: remove the mains plug.

- 1) Place the 13 mm spanner onto the cutter shaft.
- 2) place the 13 mm spanner onto the cutter fastening (E) nut.
- 3) loosen the (E) nut by turning it clockwise (fig.18).

ATTENTION: left hand thread.

- 4) remove the (E) nut, the (O) cutter and clean the shaft.
- 5) insert the new cutter, **check its direction** of rotation and screw in the (E) nut anticlockwise.

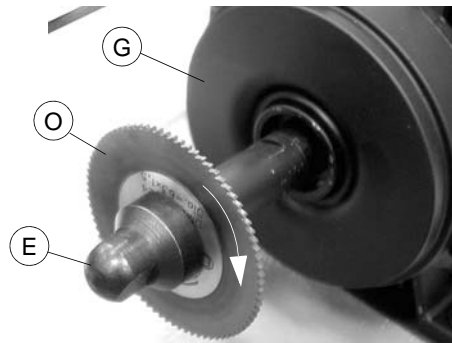

Fig. 18

7.2 Tracer point replacement

To replace the tracer point (N), proceed as follows (fig.19):

ATTENTION: unplug the machine from the mains.

- 1) Loosen and remove the tracer point locking screws (K).
- 2) remove the tracer point.
- 3) fit the new tracer point.
- 4) re-gauge the machine as described in chap. 6, page 14.

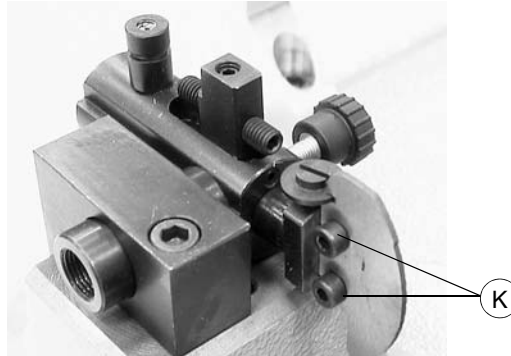

Fig. 19

7.3 Replacing the fuses

ATTENTION: remove the mains plug.

- 1) Turn the key-cutting machine so that the fuse box is easily reached.
- 2) remove the fuses box placed below the key-cutting machine socket (fig.20).
- 3) replace the fuses (U).
- 4) close the fuses box and connect the power cable.

ATTENTION: fuses must always be replaced with others of the same type (rapid) and with the same Amps (4 Amps on 230V, 10 Amps on 110V).

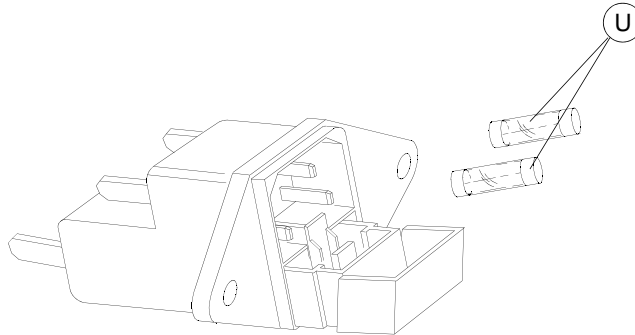

Fig. 20

8 DISPOSING OF MACHINE

To dispose the machine, it must be rendered unusable by carrying out the operations listed below:

- deactivation of the electricity supply;
- separation of the plastic and metal parts;

When these operations have been carried out, the machine can be disposed of according to the current regulations in the country of use.

Waste disposal

As CEE norms refer to specific waste (**) disposal methods for each country, the regulations current in the country where the machine is installed must be observed.

Machine

The HALLEY BKA 2000 is made up of recyclable parts.
Recycling is ecologically recommended.

Packing

The HALLEY BKA 2000 is consigned in a cardboard packing box which can be re-used if undamaged. When it is to be thrown away it is classified as solid urban waste and should be placed in the special paper collecting bins.

The protective shell containing the machine is in polymer, classified as SUW, and can therefore be placed in an ordinary waste bin.

Waste deriving from key cutting

The waste deriving from key cutting is classified special waste, but is still classified as solid urban waste, as metal wool. Such waste must be disposed of in special collection centres according to the classification assigned to them by the current EEC law. The circumstances which transform metal residue from solid urban waste into contaminated or toxic noxious waste are listed in the appendices to the current European Union regulations regarding disposal of such waste.

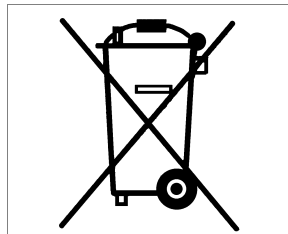

INFORMATION FOR USERS

*as per art. 10 of Directive 2002/96/CE of 27/01/2003
regarding waste from electric and electronic appliances (RAEE),*

- The symbol illustrated above, also found on the machine, indicates that it has been placed on the market and must be included in separate rubbish collection when the user wishes to dispose of it (including all components, sub-assemblies and consumables that are integrated in the product).
- For information about the collection system for such appliances please contact SILCA S.p.A. or another subject registered in the various National Rolls for other countries in the European Union. Household waste (or of similar origin) can be included in the separate collection system for urban waste.
- On purchasing a new appliance of equivalent type, the old one can be consigned to the dealer. The dealer will then contact whoever is responsible for collecting the appliance.
- Suitable separate collection of the unused appliance and its dispatch for treatment, recovery and environmentally compatible disposal, makes it possible to avoid potential negative effects on the environment and human health, and aids recycling and the recovery of the materials used.
- Unauthorised disposal of the product by users involves the application of the sanctions provided for in received Directives 91/156/CE and 91/689/CE.

(**) Waste is any substance or object deriving from human activity or natural cycles, disposed off or to be disposed off.

9 AFTER-SALES SERVICE

Ilco Orion provides full service to purchasers of the HALLEY BKA 2000 key-cutting machine. To ensure complete safety to the operator and machine, any job not specified in this manual should only be carried out by the manufacturer or recommended Ilco Orion Service Centres.

On the back cover of this manual is a list of the manufacturer's addresses; listed below are the addresses of specialized service centres.

9.1 How to request service

The guarantee attached to the HALLEY BKA 2000 ensures free repairs or replacements of faulty parts within 12 months of the date of purchase. All other service calls must be arranged by the customer with Ilco Orion or specialized Ilco Orion service centres.



VITTORIO VENETO 11/11/2005

CE DECLARATION OF MACHINE COMPLIANCE

**SILCA S.p.A. - VIA PODGORA 20 (Z.I.)
31029 VITTORIO VENETO (TV) - (ITALY)
TEL. 0438 9136 - FAX. 0438 913800**

Declares under its own responsibility that the **Key-cutting machine** model

HALLEY

complies with the requirements of the following European Directives:

European Union **DIRECTIVE 98/37/CEE** (Machines)
and with the EN 292/1 – EN 292/2 Standards

European Union **DIRECTIVE 89/336/CEE** (Electromagnetic Compatibility)
and with the EN 55014-1 / EN 61000 – 3 – 2
EN 61000 – 3 – 3 Standards

European Union **DIRECTIVE 73/23/CEE** (Low Voltage)
and with the EN 60204-1 (sections 20.2 – 20.3 – 20.4) Standards

| 02 |

General Manager Basic Production Center

Corrado Fischer